

● Description

The KT060L is an optically coupled gate that combines a light emitting diode and an integrated high gain photo detector. The output of the detector IC is an open collector Schottky clamped transistor. The internal shield provides a guaranteed common mode transient immunity specification of 10,000 V/μs for the KT060L. This unique design provides maximum AC and DC circuit isolation while achieving TTL compatibility. The KT060L is suitable for high-speed logic interfacing, input/output buffering, as line receivers in environments that conventional line receivers cannot tolerate and are recommended for use in extremely high ground or induced noise environments.

● Features

1. 10 kV/μs minimum Common Mode Rejection (CMR) at VCM = 1000V
2. High speed: 10 MBd typical
3. Guaranteed ac and dc performance over -40°C ~+110°C

● Applications

- Isolated line receiver
- Computer-peripheral interfaces
- Digital isolation for A/D, D/A conversion
- Isolation of high speed logic systems

● Truth Table

LED	OUT
ON	L
OFF	H

Note: A 0.1μF bypass capacitor must be connected between Pin 4 and 6.

● Schematic

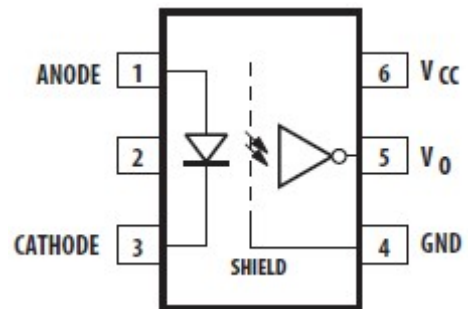

- | | |
|------------|------------------------|
| 1. Anode | 4. GND |
| 2. N.C. | 5. Vo (Voltage Output) |
| 3. Cathode | 6. Vcc |

● **Outside Dimension**

Unit : mm

P Type

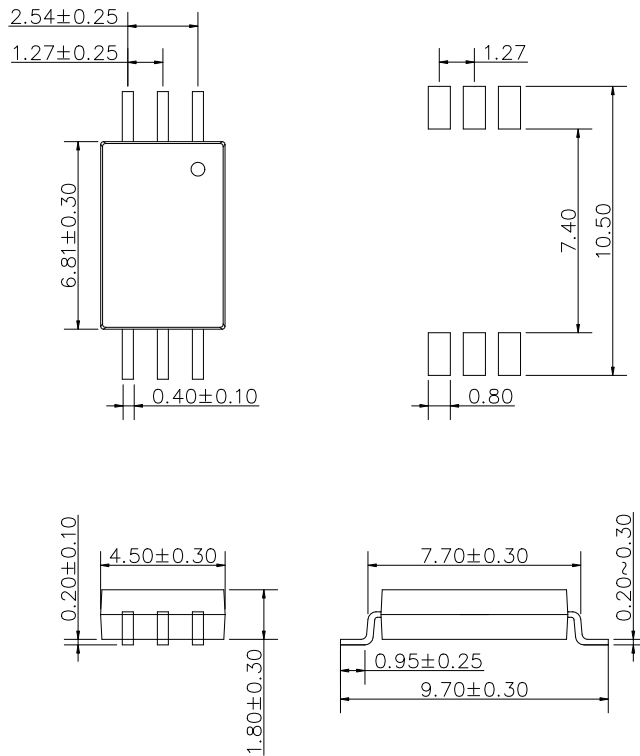

W Type

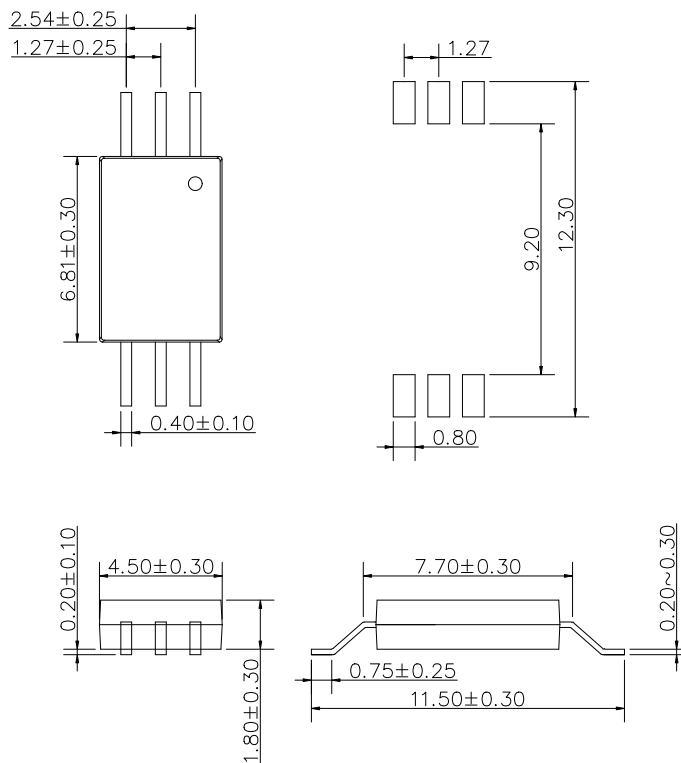

● **Device Marking**



Notes:

COSMO

060L

YWW



Y: Year code / WW: Week code
V or None : VDE option

● **Absolute Maximum Ratings**

(Ta = 25°C)

Parameter		Symbol	Rating	Unit
Input	Forward current	I _F	20	mA
	Peak transient forward current (Note 1)	I _{FPT}	1	A
	Reverse voltage	V _R	5	V
Output	Output current	I _O	50	mA
	Output voltage	V _O	7	V
	Supply Voltage	V _{CC}	7	V
Junction temperature		T _j	125	°C
Storage Temperature		T _{stg}	-55~125	°C
Operating Temperature		T _{opr}	-40~110	°C
Total Package Power Dissipation		P _T	130	mW
Lead soldering temperature(10s) (Note 2)		T _{sol}	260	°C
Isolation voltage (AC,1min.,R.H≤60%) (Note 3)		BVs	5000	Vrms
Input-Output Resistance (V _{I-O} = 500V DC) (Note 3)		R _{I-O}	10 ¹²	Ω

Note 1: Pulse width Pw ≤ 1μs,300pps.

Note 2: It is 2 mm or more from a lead root.

Note 3: Device is considered as a two terminal device: Pin1,2 and 3 shorted together, and pins 4,5 and 6 shorted together.

● **Recommend Operation Conditions**

Parameter	Symbol	Min.	Max.	Unit
Operating Temperature	TA	-40	110	°C
Supply Voltage	VCC	4.5	5.5	V
Input Current High Level	IFLH	5	15	mA
Input Voltage Low Level	VFHL	-3.0	0.8	V
Fan Out (at RL = 1 KΩ)	N		5	TTL Loads
Output Pull-up Resistor	RL	330	4K	Ω

Note 1: Detector requires a VCC of 4.5 V or higher for stable operation as output might be unstable if VCC is lower than 4.5 V. Be sure to check the power ON/OFF operation other than the supply current.

Note 2: The initial switching threshold is 1.6 mA or less. It is recommended that 2.2 mA be used to permit at least a 20% LED degradation guard band.

● **Electrical Characteristics**

(Ta = 25°C)

Parameter	Symbol	Test Condition	Min.	Typ.	Max.	Unit	
Input Forward Voltage	V _F	I _F =10mA	1.6	2.0	2.4	V	
Input Reverse Voltage	BV _R	I _R = 10μA	5	-	-	V	
Input Threshold Current	I _{TH}	VCC = 5.5V, VO = 0.6V, IOL > 13 mA	-	1.0	5.0	mA	
Input Capacitance	C _{IN}	f = 1 MHz, V _F = 0 V	-	60	-	pF	
Supply Current	High Level	I _{CCH}	VCC = 5.5V, I _F = 0 mA	-	5.6	7.5	mA
	Low Level	I _{CCL}	VCC = 5.5V, I _F = 10 mA	-	5.2	10.5	
Output current	High level	I _{OH}	VCC = 5.5V, VO = 5.5V, V _F = 0.8V	-	0.35	100	μA
Output voltage	Low level	V _{OL}	VCC = 5.5V, I _F = 5 mA, IOL(Sinking) = 13 mA	-	0.25	0.6	V

Specified over recommended temperature (TA = -40°C to +110°C, +4.5V ≤ VCC ≤ 30V), I_F(ON) = 1.6mA to 5mA, V_F(OFF) = 0V to 0.8V, unless otherwise specified. All typicals at TA = 25°C.

Note 1: Duration of output short circuit time should not exceed 10 μs.

Note 2: Input capacitance is measured between pin 1 and pin 3.

● Switching Characteristics

(Ta = 25°C)

Parameter	Symbol	Test Condition	Min.	Typ.	Max.	Unit
Propagation Delay Time to Output Low Level	t_{PHL}	VCC = 5V, IF = 7.5 mA, RL = 350Ω, CL = 15 pF	-	35	75	ns
Propagation Delay Time to Output High Level	t_{PLH}		-	60	75	
Pulse Width Distortion	PWD		-	25	40	
Rise Time	t_r		-	30	-	
Fall Time	t_f		-	3	-	
Common mode transient immunity at high level output	$ C_{MH} $	VCC = 5V, IF = 0 mA, VO(MIN) = 2V, RL = 350Ω, VCM = 1000V	10	15	-	KV / μs
Common mode transient immunity at low level output	$ C_{ML} $	VCC = 5V, IF = 7.5 mA, VO(MAX) = 0.8V, RL = 350Ω, VCM = 1000V	10	15	-	KV / μs

Over recommended operating conditions TA = -40° C to 105° C, VCC = +4.5 V to 30 V, IF(ON) = 1.6 mA to 5 mA, VF(OFF) = 0 V to 0.8 V, unless otherwise specified. All typicals at TA = 25°C.

Note 1: The tPLH propagation delay is measured from the 50% point on the leading edge of the input pulse to the 1.3 V point on the leading edge of the output pulse. The tPHL propagation delay is measured from the 50% point on the trailing edge of the input pulse to the 1.3 V point on the trailing edge of the output pulse.

Note 2: Pulse Width Distortion (PWD) is defined as $|t_{PHL} - t_{PLH}|$ for any given device.

Note 3: The difference of tPLH and tPHL between any two devices under the same test condition.

Note 4: CMH is the maximum slew rate of the common mode voltage that can be sustained with the output voltage in the logic high state, VO > 2.0 V. CML is the maximum slew rate of the common mode voltage that can be sustained with the output voltage in the logic low state, VO < 0.8 V. Note: Equal value split resistors (Rin/2) must be used at both ends of the LED.

TYPICAL PERFORMANCE CURVES & TEST CIRCUITS

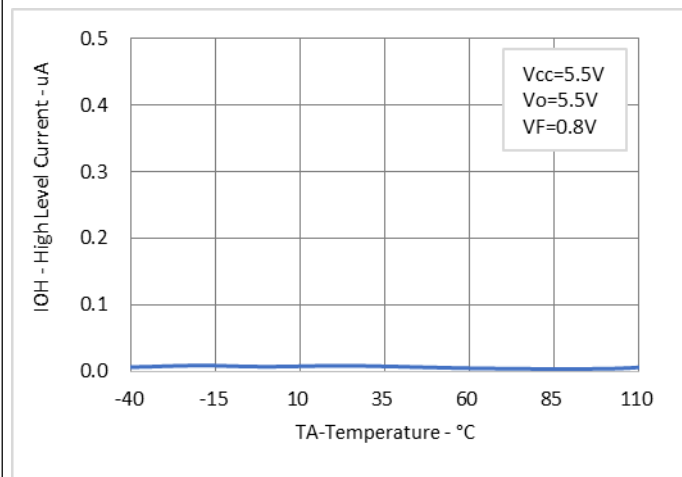
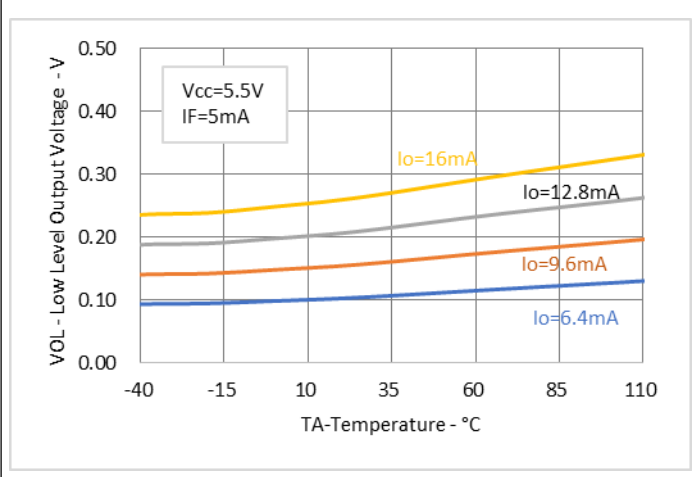
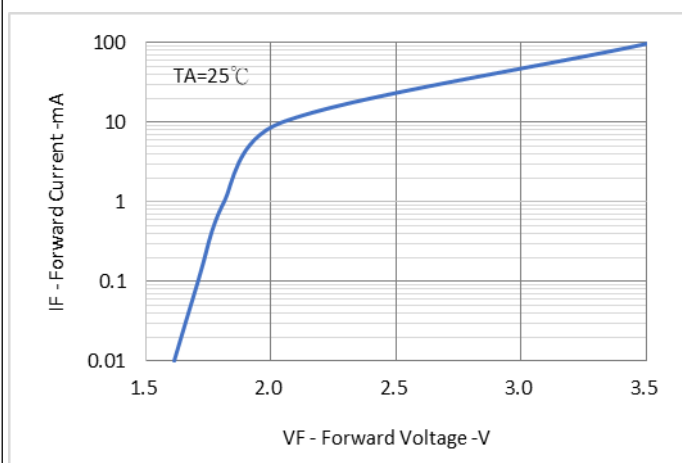
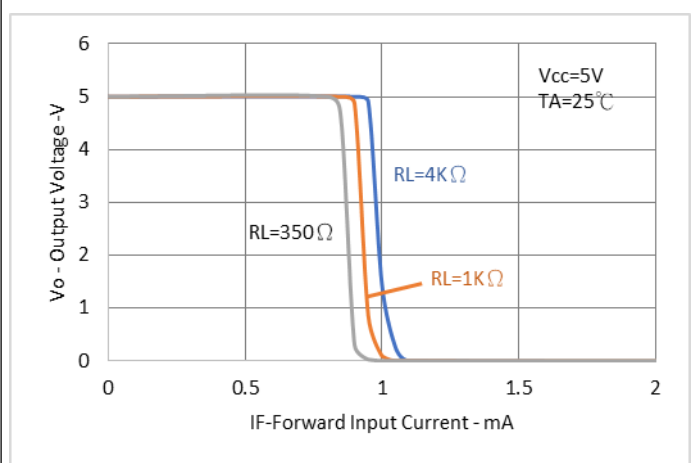
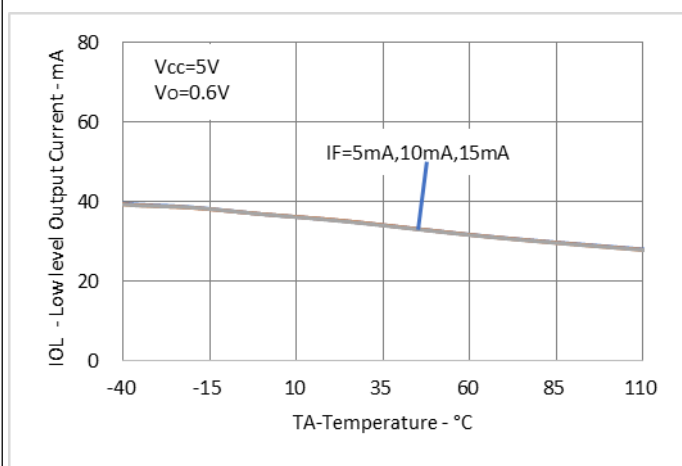
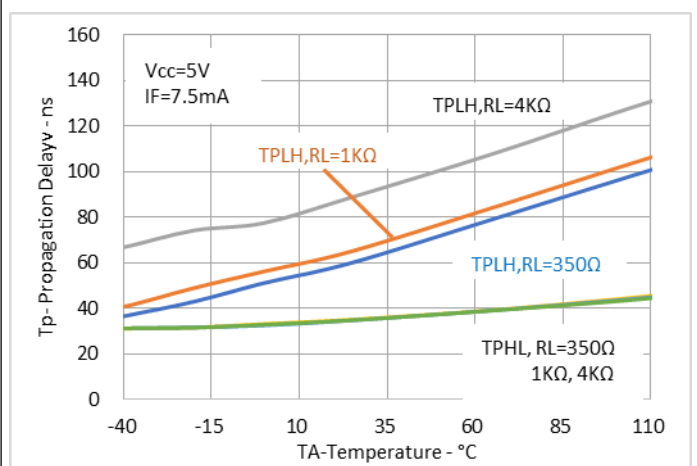
Fig.1 High Level Output Current vs. Temp

Fig.2 Low Level Output Voltage vs. Temp

Fig.3 Input Diode Forward Characteristic

Fig.4 Output Voltage vs. Input Current

Fig.5 Low Level Output Current vs. Temp

Fig.6 Propagation Delay vs. Temperature

Fig.7 Propagation Delay vs. Input Current
Fig.8 Pulse Width Distortion vs. Temperature

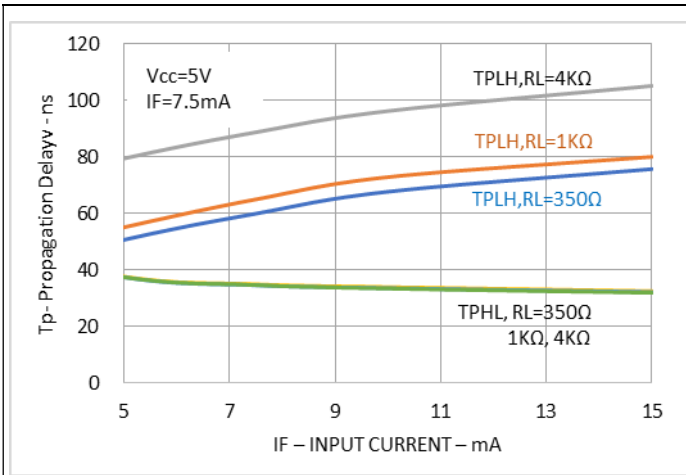

Fig.9 Rise and Fall Time vs. Temperature

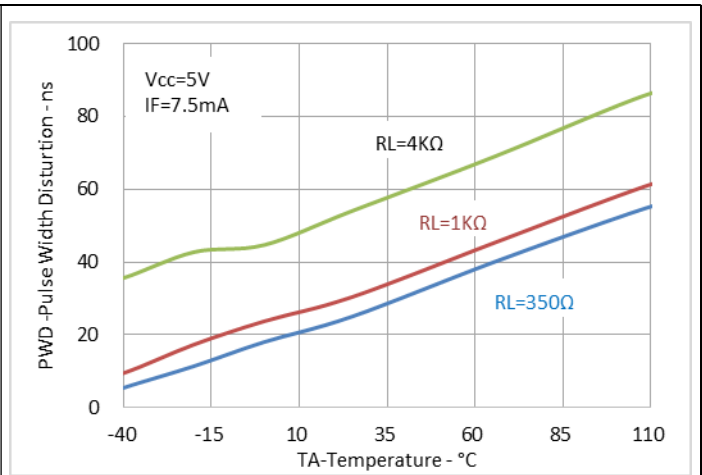
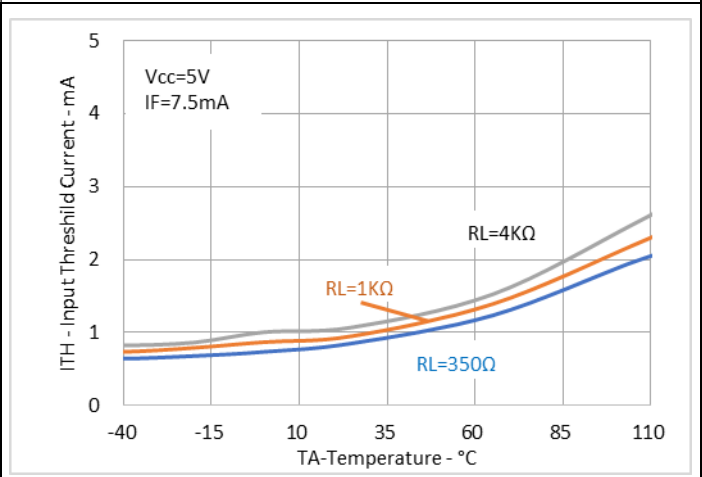
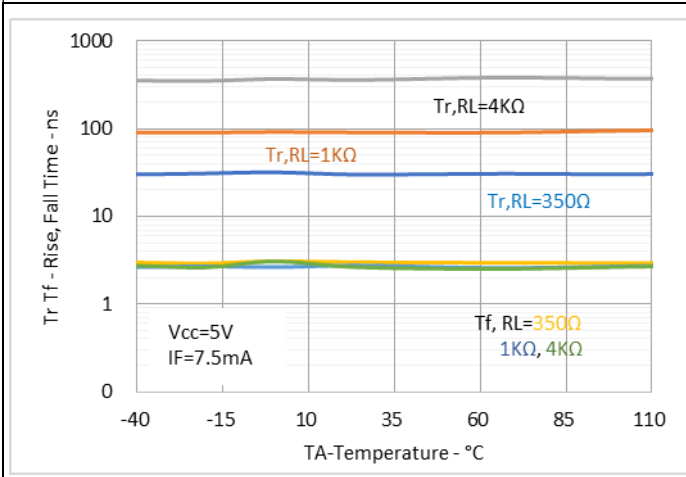
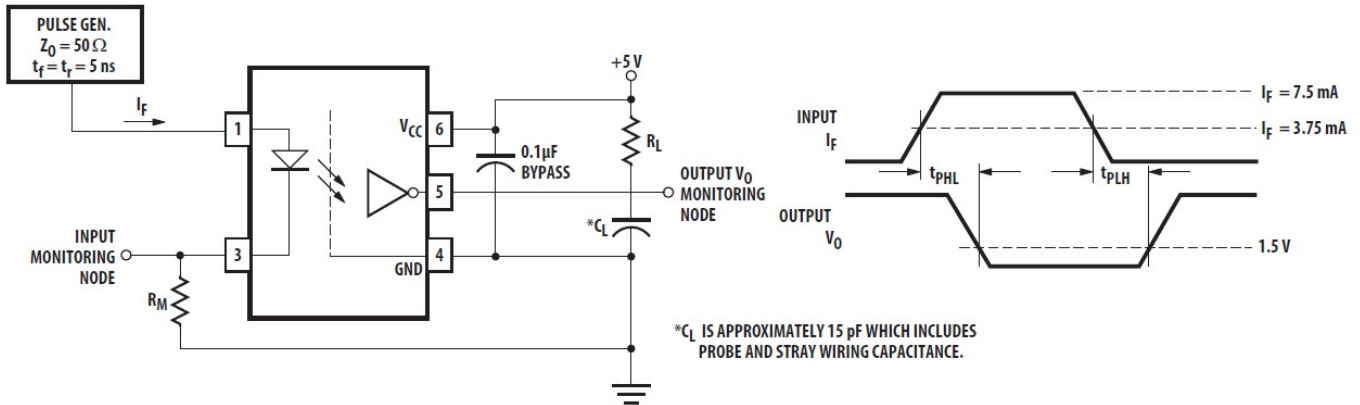

Fig.10 Input Threshold Current vs. Temp



● **Test Circuit**

Propagation delay time t_{PLH} 、 t_{PHL} 、and rise time t_r , fall time t_f



Common Mode Transient Immunity Test Circuit and Typical Waveforms

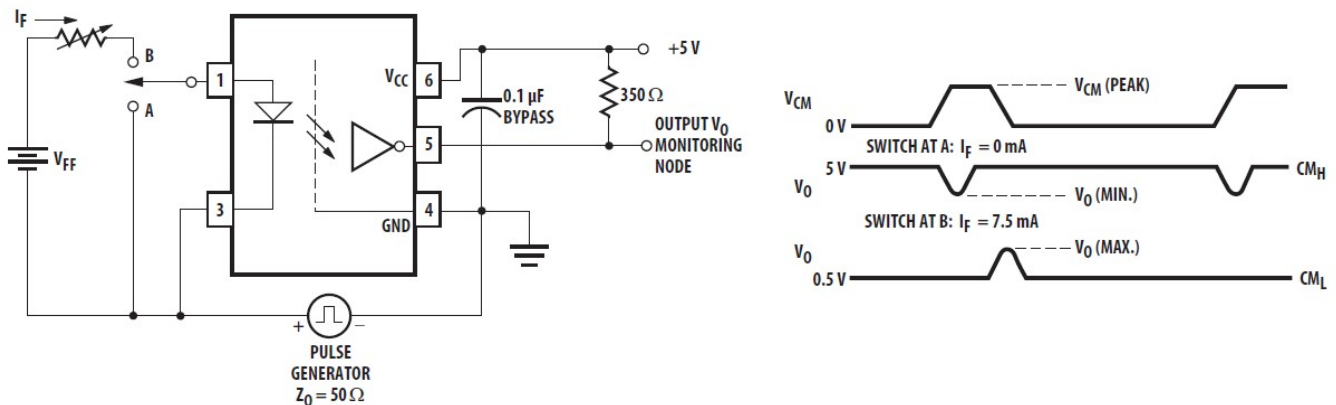

* $C_{ML}(C_{MH})$ is the maximum rate of rise (fall) of the common mode voltage that can be sustained with the output voltage in the low (high) state.

● **Recommended Soldering Conditions**

IR Reflow soldering

One time soldering reflow is recommended within the condition of temperature and time profile shown below. Do not solder more than three times.

Recommended Temperature Profile of Infrared Reflow

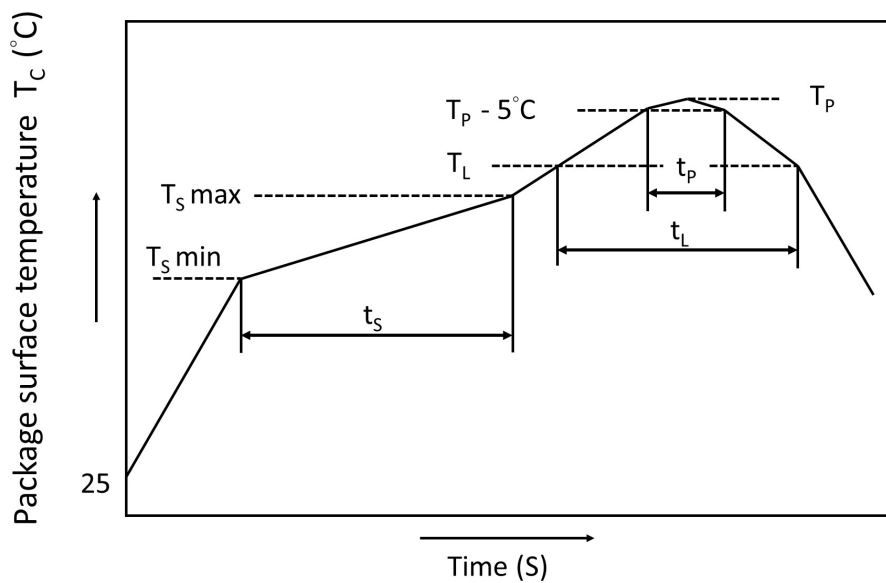

	Symbol	Min	Max	Unit
Preheat temperature	T_s	150	200	$^\circ\text{C}$
Preheat time	t_s	60	120	s
Ramp-up rate (T_L to T_P)			3	$^\circ\text{C/s}$
Liquidus temperature	T_L	217		$^\circ\text{C}$
Time above T_L	t_L	60	100	s
Peak Temperature	T_P		260	$^\circ\text{C}$
Time during which T_c is between ($T_P - 5$) and T_P	t_p		20	s
Ramp-down rate			6	$^\circ\text{C/s}$

● **Numbering System**

KT060L X (Y)-(Z)

Notes:

KT060 = Part No.

X = Lead form option (P or W)

Y = Tape and reel option (TLD or TRU)

Z = VDE option (V or None)

Option	Description	Packing quantity
P (TLD)	surface mount type package + TL tape & reel option	3000 units per reel
P (TRU)	surface mount type package + TR tape & reel option	3000 units per reel
W (TLD)	long creepage distance for surface mount type package + TLD tape & reel option	3000 units per reel
W (TRU)	long creepage distance for surface mount type package + TRU tape & reel option	3000 units per reel

● **Recommended Pad Layout for Surface Mount Lead Form**

1. Surface mount type

6LSOP-P type

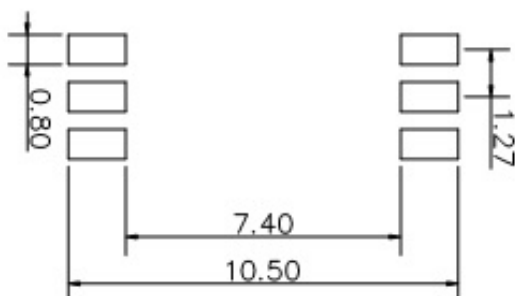
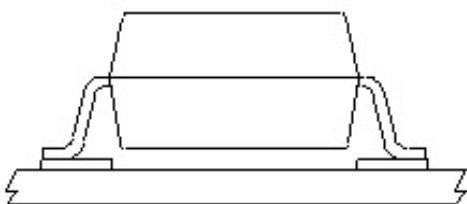

2. Long creepage distance for surface mount type

6LSOP-W type

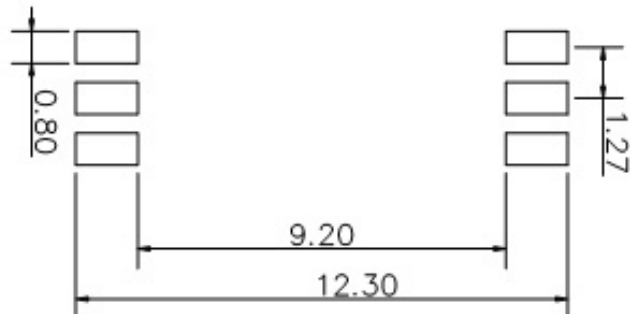
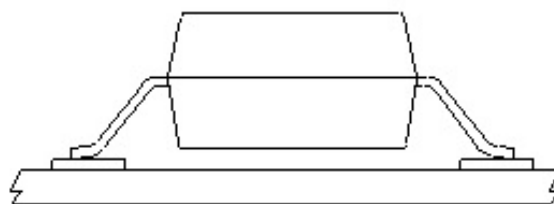

Unit :mm

<http://www.cosmo-ic.com>

● **LSOP 6 Carrier Tape & Reel**

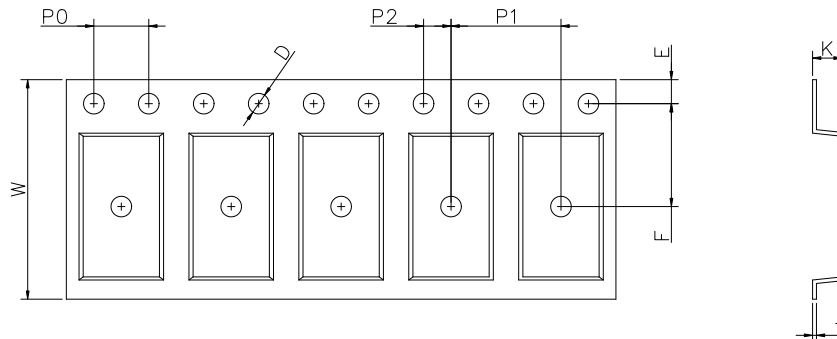

Dimension Symbol	D	E	F	P0	P1	P2	t	W	K
P type Dimension (mm)	1.5±0.1	1.75±0.1	7.5±0.1	4.0±0.1	8.0±0.1	2.0±0.1	0.3±0.1	16.0±0.3	2.15±0.1
W type Dimension (mm)	1.5±0.1	1.75±0.1	11.5±0.1	4.0±0.1	8.0±0.1	2.0±0.1	0.3±0.1	24.0±0.3	2.52±0.1

TRU

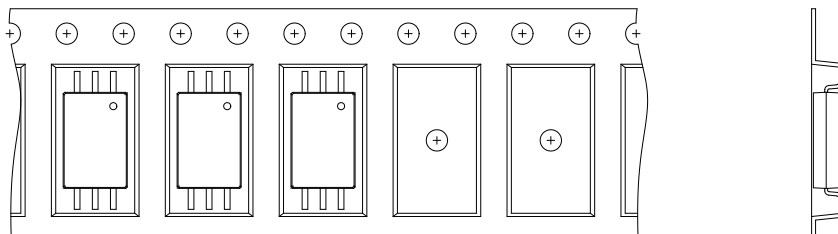

TLD

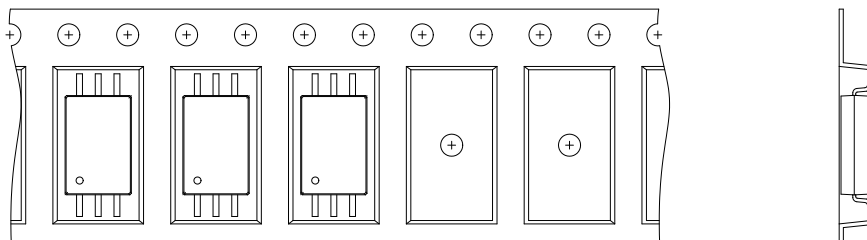

- **Application Notice**

The statements regarding the suitability of products for certain types of applications are based on cosmo's knowledge of general applications of cosmo products. Such statements are not binding statements about the suitability of products for a particular application. It is the customer's responsibility to verify the specifications are suitable for use in a particular application. Customers are solely responsible for all aspects of their own product design or applications. The parameters provided in the datasheet may vary in different applications and performance may vary over time. All operating parameters (including typical parameters) must be validated by customer's technical experts for different applications. cosmo assumes no liability for customer' product design or applications. Product specifications do not expand or otherwise change cosmo's terms and conditions of purchase, including but not limited to the warranty expressed therein.

When using cosmo products, please comply with safety standards and instructions. cosmo has no liability and responsibility to the damage caused by improper use of the instructions specified in the specifications.

cosmo products are designed for use in general electronic equipment such as telecommunications, office automation equipments, personal computers, test and measurement equipments, consumer electronics, industrial control, instrumentation, audio, video.

cosmo devices shall not be used in equipment that requires higher level of reliability and safety, such as nuclear power control equipment, telecommunication equipment(trunk lines), space application, medical and other life supporting equipments, and equipment for aircraft, military, automotive or any other application that can cause human injury or death.

cosmo reserves the right to change the specifications, data, characteristics, structure, materials and other contents at any time without notice. Please contact cosmo to obtain the latest specification.

cosmo disclaim any and all liability for any errors, inaccuracies or incompleteness contained in any datasheet or in any other disclosure relating to any product.